

# 2.5" SATA Solid State Disk DATA SHEET

廣穎電通股份有限公司

Silicon Power Computer & Communications Inc.

TEL: 886-2 8797-8833 FAX: 886-2 8751-6595

台北市114 內區洲子街106 號7 樓

7F, No.106, ZHO-Z ST. NEIHU DIST, 114, TAIPEI, TAIWAN, R.O.C.

## Revision History

Revision No.	Date	Remarks
0.1	2008/06/17	First issue
1.0	2008/07/07	Add P/N list
1.1	2008/08/19	Dimension revised
1.2	2008/09/01	Update performance

### Table of contents

1. Description .....	2
2. Placement .....	2
3. Specifications.....	3
3.1.Power Consumption : .....	3
3.2.Physical Specification : .....	3
3.2.1. Storage Capacity : .....	3
3.2.2. Sector Size : .....	3
3.2.3. Power Supply : .....	3
3.3. Performance Specification : .....	3
3.3.1. Transfer Mode : .....	3
3.3.2. Wear-leveling .....	3
3.3.3. Performance.....	4
3.4. Environmental Specification : .....	4
3.4.1. Temperature : .....	4
3.4.2. Humidity.....	4
3.4.3. Vibration : .....	4
3.4.4. Shock : .....	4
3.5.Reliability Specification : .....	4
3.5.1. Insertions : .....	4
3.5.2. Endurance : .....	4
3.5.3. Data Retention : .....	4
3.5.4. ECC(Error Correction code) : .....	4
3.6.Compliance Specification : .....	4
4. Block Diagram .....	5
5. Pin Assignments and Pin Type .....	6
6. Electrical Characteristics .....	7
7. Command Table .....	8
8. P/N List.....	8

## 1. Description

The 2.5" SATA Solid State Disk is designed with Reliability, Capacity, Performance and Flexibility as the four main criteria.



## 2. Placement

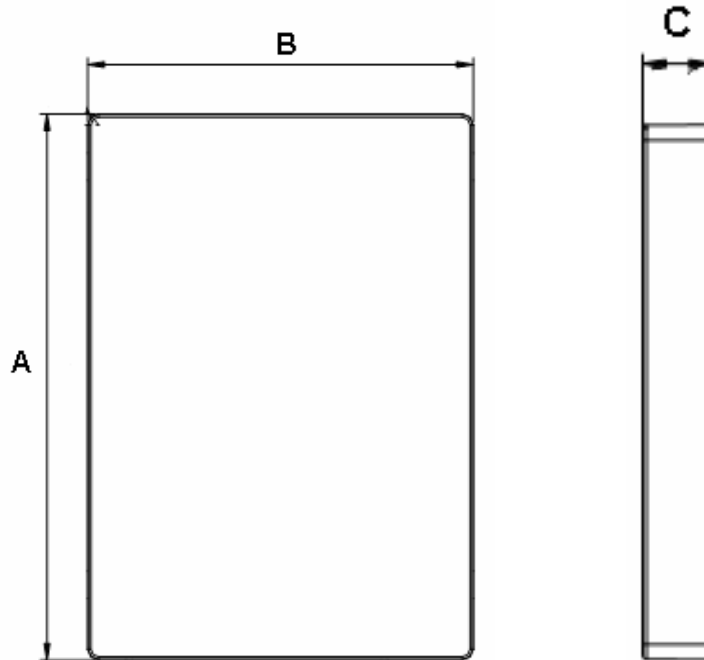

Side	Millimeters	Inches
A	100.00±0.2	3.94±0.08
B	69.85±0.100	2.75±0.004
C	9.15±0.100	0.36±0.004

### 3. Specifications

#### 3.1. Power Consumption :

##### 1. 2.5" SATA SSD 32GB SLC

File Copy	Read(MIN)	290mA
	Read(MAX)	300mA
	Write(MIN)	340mA
	Write(MAX)	360mA
Sleep (idle)		220mA

##### 2. 2.5" SATA SSD 32GB MLC

File Copy	Read(MIN)	290mA
	Read(MAX)	300mA
	Write(MIN)	380mA
	Write(MAX)	420mA
Sleep (idle)		220mA

Note : DC 5V±10% / 25°C

#### 3.2. Physical Specification :

##### 3.2.1. Storage Capacity :

- MLC - 8GB/16GB/32GB/64GB/128GB
- SLC - 8GB/16GB/32GB/64GB

##### 3.2.2. Sector Size :

- 512bytes

##### 3.2.3. Power Supply :

- SATA interface I/O at 5.0V ±10%

#### 3.3. Performance Specification :

##### 3.3.1. Transfer Mode :

- Support SATAI、SATAII

##### 3.3.2. Wear-leveling

- Static & Dynamic

### 3.3.3. Performance

Model P/N	Read(MB/s)	Write(MB/s)
SP008GBSSD750S25 ~ SP064GBSSD750S25	160(Max)	145(Max)
SP008GBSSD650S25 ~ SP128GBSSD650S25	160(Max)	91(Max)

### 3.4. Environmental Specification :

#### 3.4.1. Temperature :

- Operating temperature : 0°C ~ 70°C
- Storage Temperature : -40°C ~ 85°C

#### 3.4.2. Humidity

- Operating Humidity : 5%~95%
- Non - Operating Humidity : 5%~95%

#### 3.4.3. Vibration :

- 15 G peak-to-peak max

#### 3.4.4. Shock :

- 1500 G Max

### 3.5. Reliability Specification :

#### 3.5.1. Insertions :

- 10,000 times

#### 3.5.2. Endurance :

- 100,000 Program/Erase Cycles

#### 3.5.3. Data Retention :

- 10 Years

#### 3.5.4. ECC(Error Correction code) :

- 8/15bits in 512 Data bytes

### 3.6. Compliance Specification :

- CE
- FCC
- ROHS

## 4. Block Diagram

The following figure is the internal block diagram

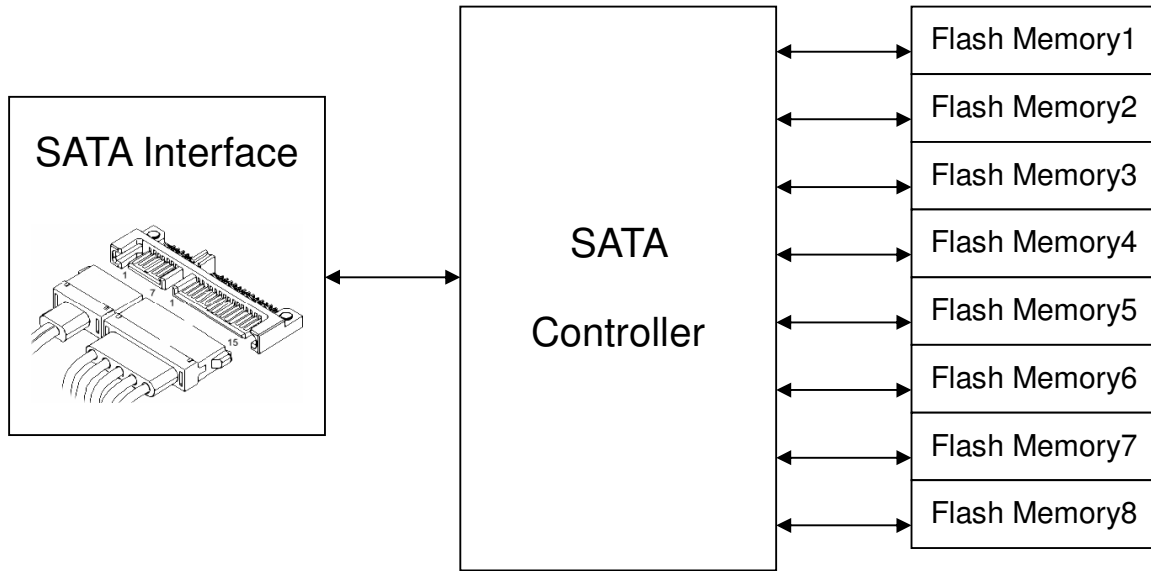

Figure 1 Internal Block Diagram

## 5. Pin Assignments and Pin Type

	Pin Num	Signal Name	Description
Signal Segment	S1	GND	Ground
	S2	A+	Differential Signal Pair A
	S3	A-	
	S4	GND	Ground
	S5	B-	Differential Signal Pair B
	S6	B+	
	S7	GND	Ground
Power Segment	P1	V33	3.3V Power
	P2	V33	3.3V Power
	P3	V33	3.3V Power
	P4	GND	Ground
	P5	GND	Ground
	P6	GND	Ground
	P7	V5	5V Power
	P8	V5	5V Power
	P9	V5	5V Power
	P10	GND	Ground
	P11	Reserved	-
	P12	GND	Ground
	P13	V12	12V Power
	P14	V12	12V Power
	P15	V12	12V Power

## 6. Electrical Characteristics

### Absolute Maximum Rating

Parameter	Symbol	Min	Max
Analog power supply	AVDDH	-0.5 V	6 V
Digital I/O power supply	DVDD	-0.5 V	6 V
Digital I/O input voltage	$V_{I(D)}$	-0.4 V	DVDD + 0.4V
Storage temperature	$T_{STORAGE}$	-40 °C	85°C

### Recommended Power Supply Operating Conditions

Parameter	Symbol	Min	Typical	Max
Operation digital power supply	DVDD	3.0 V	3.3 V	3.6 V
Operation analog power supply	AVDDH	3.0 V	3.3 V	3.6 V
Ambient operation temperature	$T_A$	0 °C		70 °C
Junction Temperature	$T_J$	0 °C		125 °C

### I/O DC Characteristics

Parameter	Symbol	Min	Typical	Max
Input low Voltage	$V_{IL}$			0.8 V
Input high Voltage	$V_{IH}$	2.0 V		
Output low Voltage	$V_{OL}$	0 V		0.4 V
Output high Voltage	$V_{OH}$	2.6 V		3.6 V

## 7. Command Table

Command Name	Code	Command Name	Code
RECALIBRATE	10h	STADBY	E2h
READ SECTOR(S)	20h	IDLE	E3h
WRITE SECTOR(S)	30h	CHECK POWER	E5h
READ VERIFY SECTOR(S)	40h	SLEEP	E6h
INITIALIZE DEVICE PARAMETERS	91h	FLUSH CACHIE	E7h
DOWNLOAD MICRICODE	92h	IDENTIFY DEVICE	ECh
SMART	B0h	SET FEATURES	EFh
READ MULTIPLE	C4h	SECURITY SET PASSWORD	F1h
WRITE MULTIPLE	C5h	SECURITY UNLOCK	F2h
SET MULTIPLE MODE	C6h	SECURITY ERASE PREPARE	F3h
READ DMA	C8h	SECURITY ERASE UNIT	F4h
WRITE DMA	CAh	SECURITY FREEZE LOCK	F5h
STANDBY IMMEDIATE	E0h	SECURITY DISABLE PASSWORD	F6h
IDLE IMMEDIATE	E1h		

## 8. P/N List

**SP XXXGB SSD XXX S25**  
 1            2            3            4            5

1. SILICON POWER Product
2. Capacity : 008GB / 016GB /032GB / 064GB / 128GB
3. Solid State Disk
4. 750 = SLC / 650 = MLC
5. S25= 2.5" SATA